

PROTEXO[®]

●●● Ergonomics

PRODUCT CATALOG

Ergonomic Standing Desks
& Accessories





Introduction to our ergonomic desks

- Flow II 03
- Flow Duo 05
- Flow Corner 07
- Flow Max 09
- Flow Pro 11
- Flow I 13
- Desk Accessories 15

Prospecta BV

Scheestraat 31a, 9270 Kalken

www.protexo.be - info@protexo.be - +32 (0)9 397 19 91

Flow II

Dual Motor 3-Stage

Specifications:

- Height range: 580-1280mm
- Speed: 40mm/s
- Load capacity: 125kg
- Power: 100-240V
- Sound level: <50dB

Features:

- Square holeless columns
- 3-Stage columns
- Dual motor

Recommended tabletop dimensions:

- Width: 1200-2000mm
- Depth: 600-800mm

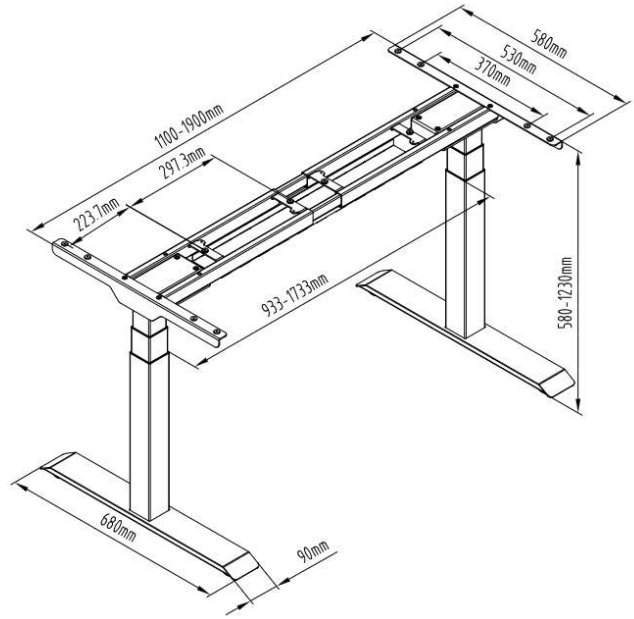

Control panel:



Frame colors:



Certificates



Flow Duo



Frame colors:



Control panel:



Quad Motor 3-Stage

Specifications:

- Height range: 580-1280mm
- Speed: 40mm/s
- Load capacity: 125kg
- Power: 100-240V
- Sound level: <50dB

Features:

- Square holeless columns
- 3-Stage columns
- Quad motors

Recommended tabletop dimensions:

- Width: 1200-2000mm
- Depth: 600-800mm

Certificates

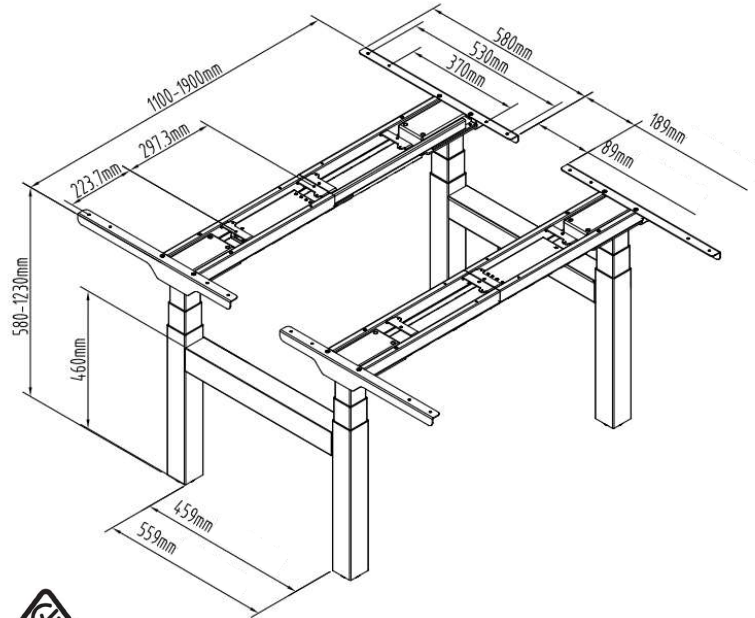

Flow Corner

Specifications:

- Height range: 580-1230mm
- Speed: 40mm/s
- Load capacity: 150kg
- Power: 100-127/200-240V
- Sound level: <50dB

Features:

- Square holeless columns
- 3-Stage columns
- Triple motor

Recommended tabletop dimensions:

- Width: 1200-2000mm
- Depth: 600-800mm



Frame colors:



Control panel:



Triple Motor 3-Stage

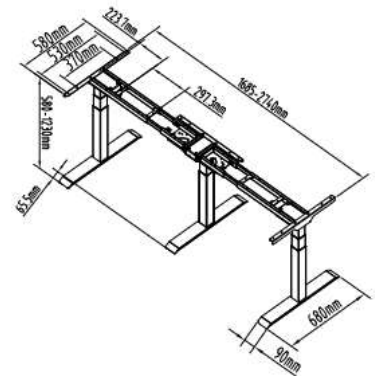
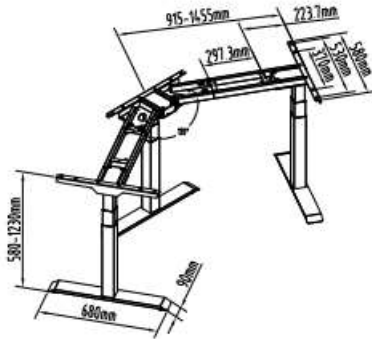
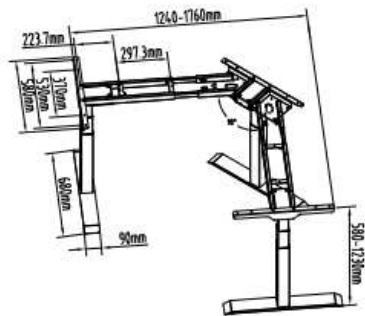

Certificates



Flow Max

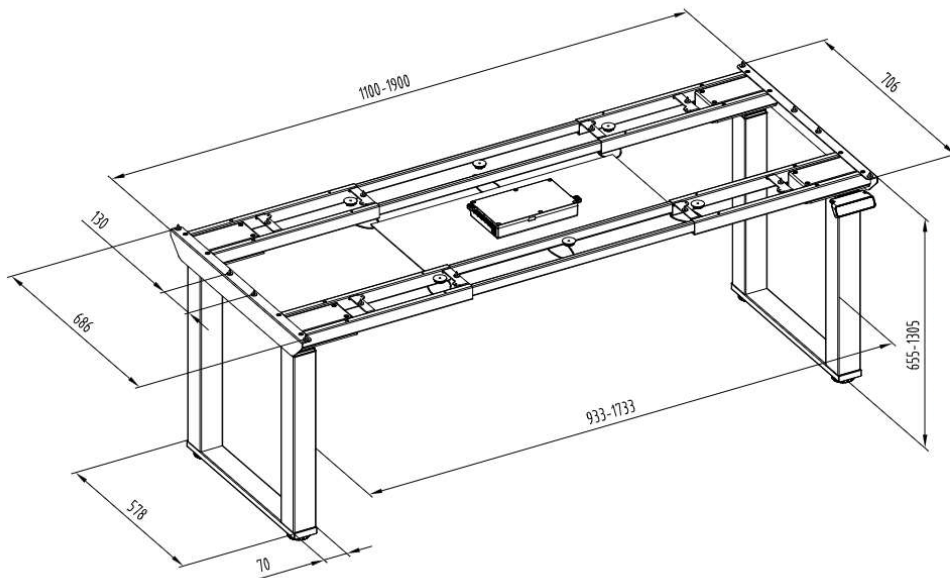

Quad Motor 3-Stage



Specifications:

- Height range: 605-1255mm
- Speed: 40mm/s
- Load capacity: 300kg
- Power: 100-240V
- Sound level: <50dB

Features:

- U-shaped column design
- 3-Stage columns
- Quad motor

Recommended tabletop dimensions:

- Width: 1800-2400mm
- Depth: 800-1000mm

Certificates



Frame colors:



Control panel:



Flow Pro

Specifications:

- Height range: 635-1285mm
- Speed: 40mm/s
- Load capacity: 125kg
- Power: 100-240V
- Sound level:<50dB

Features:

- Flat oval columns
- 3-Stage columns
- Quad motor

Recommended tabletop dimensions:

- Width: 1200-2000mm
- Depth: 600-800mm

Certificates



Frame colors:



Control panel:



Dual Motor 3-Stage

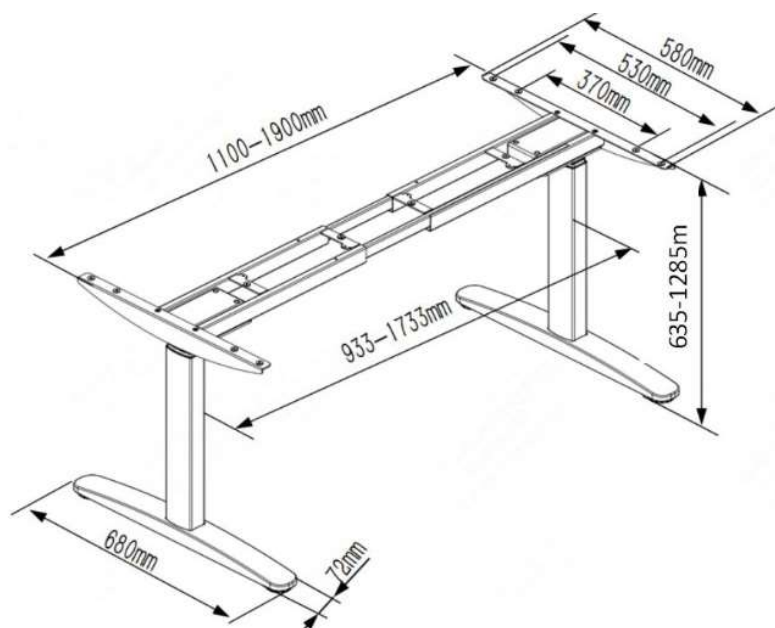

Flow I

Specifications:

- Height Range: 710-1210mm
- Speed: 25mm/s
- Load Capacity: 70kg
- Power: 100-240V
- Sound level: <50dB

Features:

- Rectangular column
- 2-stage columns
- Single motor

Recommended tabletop Dimensions:

- Width: 1000-1600mm
- Depth: 500-800mm

Certificates



Frame colors:



Control panel:



Single Motor 2-Stage

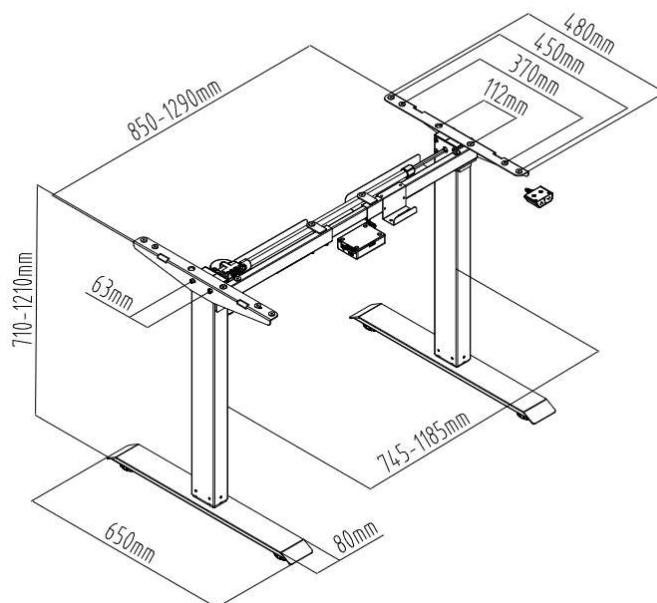

Desk accessories

Monitor arms



Acoustic panels

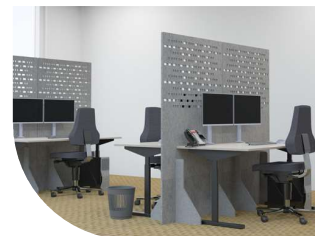

White-, chalk- & glassboards



Available tabletop colors:

White



Platina white



Light gray



Black



Acacia



Birch



Vicenza oak



Halifax oak



PROTEXO[®]
●●● Ergonomics

Prospecta BV

Scheestraat 31a, 9270 Kalken

www.protexo.be - info@protexo.be - +32 (0)9 397 19 91